



Chiltern House Stocking Lane Hughenden Valley
High Wycombe Buckinghamshire HP14 4ND UK

t +44 (0) 1494 569 800 f +44 (0) 1494 564895
e cif@chilternfire.co.uk w www.chilternfire.co.uk

Moralt
Lamincore Doorsets
30 Minutes Fire Resistance

Report reference: Chilt/A07154

Issue date: 14 September 2007
Valid until: 14 September 2012

Prepared for: Moralt Tischlerplatten GmbH & Co. KG
Lenggrieser Straße 52
D-83646 Bad Tolz
Germany

This document is confidential and remains the property of Chiltern International Fire Ltd.

The legal validity of this document can be claimed only on presentation of the complete document.

Contents

	Page No
1 Introduction	3
2 General Specification Of Construction	3
3 Leaf Sizes And Configurations.....	3
4 Leaf Size Adjustment.....	4
5 Overpanels.....	4
6 Glazing.....	4
8 Facing Materials	5
9 Lippings.....	5
10 Door Frames	6
11 Intumescent Materials	7
12 Adhesives.....	7
13 Tested Ironmongery	7
14 Additional & Alternative Ironmongery.....	8
15 Door Gaps.....	10
16 Fixings.....	10
17 Sealing to Structural Opening.....	10
18 Smoke Control.....	10
19 Conclusion.....	11
20 Declaration by the Applicant	11
21 Limitations	12
22 Validity.....	12
Appendix A - Test Data	13
Appendix B - Glazing Systems	14
Appendix C - Revisions	15
Appendix D - Data Sheets	16

The legal validity of this report can only be claimed on presentation of the complete report.

1 Introduction

This document constitutes a global assessment relating to Moralt Tischlerplatten GmbH & Co. KG, 30 minute timber based doorsets. The assessment uses established extrapolation and interpretation techniques in order to extend the scope of application by determining the limits for the design based on the tested constructions and performances obtained. The assessment is conducted in terms of BS476 : Part 22 : 1987.

2 General Specification Of Construction

The primary tested construction for doorsets to this design comprises the following:

		Species/type	Dimensions (mm)	Density (kg/m ³)
Stiles		None fitted	-	-
Rails		None fitted	-	-
Core		Spruce ply veneers	40.5 thick x 4.6 (±1) wide	450
Facings		Ilomba cross grain veneer	Total 1.5-2 thick	500
Adhesive	Lipping	Urea formaldehyde	-	-
	Facings	Melamine urea formaldehyde or urea formaldehyde	-	-
	Core	PVAC (class D4 – BSEN 204: 1991)	-	-
Lippings - all edges		Rock maple	9 thick	650

- The minimum leaf thickness must be 43.5mm (excluding decorative facings)

3 Leaf Sizes And Configurations

It can be seen from the list of fire resistance tests contained in appendix A, that the most demanding configuration tested is the unlatched, single acting, double leaf doorset and therefore extrapolation is based primarily on this test. The approval for increased leaf dimensions is based on the margin of the designs over performance above 30 minutes integrity and the characteristics exhibited during test.

Unequal leaf double doorsets are covered by this assessment with no restriction on the smaller leaf dimension, providing the main leaf remains within the permitted size limits. Doorsets containing leaves with smaller dimensions than those stated are deemed to be automatically covered.

Data sheets specifying the maximum approved leaf sizes and graphs showing the permitted gradient between maximum height and width are contained in appendix D.

4 Leaf Size Adjustment

The manufactured height or width of door leaves to this design may be reduced in height and width with out restriction. If adjustments are made to lippings, these must not be reduced below the dimensions stated in section 9.

5 Overpanels

Overpanels of the same construction as the door leaves may be used with this doorset design only when fitted with a transom. The transom must be of the same section and material assessed for the door frames, mortice and tenon jointed (with no gaps) or screwed in to the jambs and bonded with urea formaldehyde. Overpanels must be fixed by screwing through the rear of the frame with steel screws passing at least 30mm into the centre line of the overpanel. Fixings must be no more than 100mm from each corner and a maximum of 250mm centres in between. The intumescent seals specified for the jambs in appendix D, must also be fitted to all edges of the overpanel. The seals may be fitted in the overpanel edges or alternatively in the frame reveal. Maximum overpanel heights are as follows. Overpanels may be increased in height up to the stated combined height for the assembly, with a corresponding proportional decrease in leaf height:

- Single doorsets - 2000mm
- Double doorsets - 1500mm

6 Glazing

The testing conducted demonstrated that the design is capable of tolerating glazed apertures, which are therefore acceptable within the following parameters.

The maximum assessed glazed area is 0.72m², whilst the glazing system must be one of the following tested proprietary systems:

- | | |
|---------------------|-------------------------------|
| 1. THERM-A-STRIP 30 | Intumescent Seals Ltd |
| 2. FIREGLAZE 30 | Sealmaster Ltd |
| 3. SYSTEM 36 | Lorient Polyproducts Ltd |
| 4. FF1 | Lorient Polyproducts Ltd |
| 5. R8913 | Reddiplex Group Plc |
| 6. FIRESTRIP 30 | Hodgsons Sealants Ltd |
| 7. PYROGLAZE 30 | Mann McGowan Fabrications Ltd |

Glazed openings must not be less than 100mm from any door edge. Multiple apertures are acceptable up to the maximum total assessed area, with a minimum dimension of 80mm between apertures. The aperture shape is not restricted, providing the intumescent material and beads are proven (by fire resistance test) to be compatible with that shape.

Assessed glass types are:

- | | |
|-----------------------|-----------------------|
| 1. 6 & 7mm PYROSHIELD | Pilkington Glass Ltd |
| 2. 6mm PYRAN S | Schott Glass Ltd |
| 3. 7mm PYROGUARD | CGI Ltd |
| 4. 7mm PYROBELITE | AGC Flat Glass Europe |
| 5. 7mm PYRODUR PLUS | Pilkington Glass Ltd |
| 6. 10mm PYRODUR | Pilkington Glass Ltd |

The legal validity of this report can only be claimed on presentation of the complete report.

7. 12mm PYROBEL	AGC Flat Glass Europe
8. 14mm SWISSFLAM LITE	Vetrotech Saint Gobain Ltd
9. 15mm PYROSTOP	Pilkington Glass Ltd
10. 16mm PYROBEL	AGC Flat Glass Europe

Note: All glass types must be fitted strictly in accordance with the manufacturer's tested details/installation requirements.

False timber beads may be applied across the glass face with glass types 4-10, by bonding the timber either with an intumescent mastic, silicon, or by using an 0.5-1mm thick self adhesive intumescent tape.

8 Facing Materials

The primary facing material evaluated by the tested specimens was as follows:

- 1.5-2mm thick Ilomba cross grain veneer

Facings up to a maximum thickness of 3mm are considered to have limited structural and burn through influence upon fire resisting doors. We therefore consider that the following alternative materials may be assessed:

- 3mm thick MDF with a minimum density of 750kg/m³
- 3mm thick Particleboard with a minimum density of 680kg/m³

Test CFR0706151 evaluated the performance of an alternative thickness of chipboard facing, compared to the primary data. Therefore, single leaf doorsets within the leaf size range defined on page 17, may be used with the following facing specification:

- 6mm thick Particleboard with a minimum density of 680kg/m³

Additional timber veneers, foils, PVC and plastic laminates up to 2mm thick are acceptable in addition to planted timber mouldings, since these elements would degrade rapidly under test conditions without significant effect. Laminates must not be applied to the edges of doors. Metallic facings are not approved.

9 Lippings

The minimum lipping specifications are as follows:

SQUARE	9-19mm thick
ROUNDED	11-21mm thick with maximum of 2mm rounding
REBATED	20-30mm with an equal 12mm deep rebate (single doorsets only)

All edges of the leaves are to be lipped with hardwood with a minimum density of 640kg/m³ and to class J10 as specified in BS EN 942: 1996.

10 Door Frames

Doorframe timber must be a softwood or hardwood with a minimum density of 510kg/m³ and be to class J10 as specified in BS EN 942: 1996.

The minimum timber door frame section must be 70mm x 32mm. A 12mm deep planted or rebated from solid stop is adequate for single acting frames whilst double acting frames must be scalloped or square. If frames are square, the maximum radius to the corners of the leaf is 8mm. Frame joints must be mortice and tenoned, nailed or screwed and with no gaps. The following diagram depicts the assessed frame profiles and dimensions:

A = 70mm B = 32mm C = 12mm R = Radius of floorspring

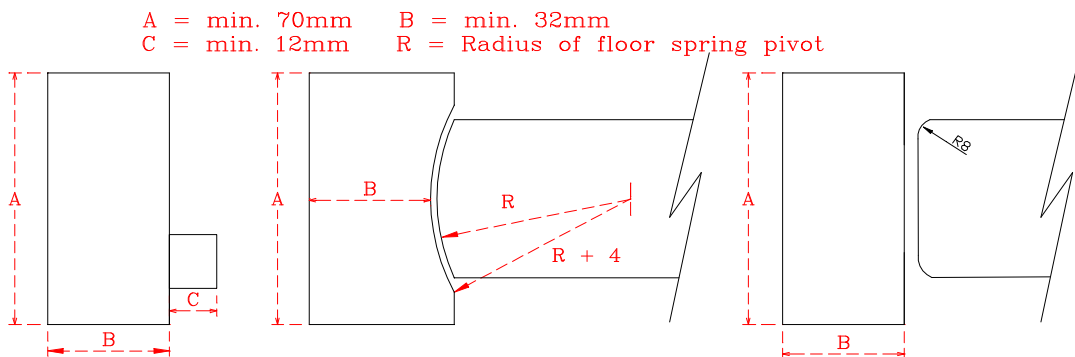

The following diagrams indicate acceptable door frame installations. Frames fitted into proprietary steel stud partitions must use architrave and frame to partition sealing methods in accordance with the manufacturers tested details.

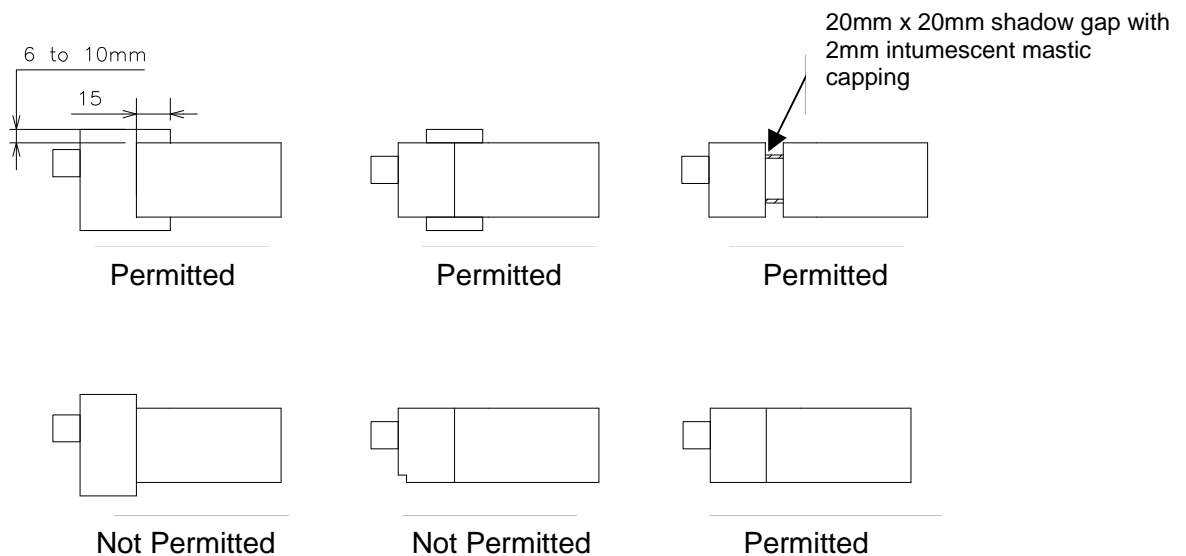

The legal validity of this report can only be claimed on presentation of the complete report.

11 Intumescent Materials

It is important that the type, size and fitting detail for the intumescent seals remains as tested. These products can often exhibit significantly different characteristics which could alter the performances obtained during test and therefore they must not be considered interchangeable, irrespective of whether the product has been tested and the seal dimensions are maintained.

The intumescent materials tested for this doorset design are as follows:

Application	Location	Product/Manufacturer
Edge seals	One meeting edge and centrally in the frame reveal or leaf edges	Therm-A-Seal – Intumescent Seals Ltd
Hinges	Under both hinge blades (leaves over 2500mm high)	G30 – Intumescent Seals Ltd
Locks/latches	Under forend & keep	1mm thick Therm-A-Strip, G30, Interdens or tested acrylic intumescent mastic
Top Pivots & Flush bolts	Lining all sides of the mortices	1mm thick Therm-A-Strip, G30 or Interdens

The full seal specification for each configuration is shown in appendix D.

12 Adhesives

The following adhesives must be used in the construction of doorsets to this design:

Location	Product
Facings	Urea formaldehyde
Lippings	Urea formaldehyde
Core	PVAC (class D4 – BSEN 204: 1991)

13 Tested Ironmongery

The following ironmongery has been successfully incorporated in the tests on doorsets to this design:

	Make/type	Size (mm)
Hinges	Royde and Tucker H101 lift off hinges	100 x 33 (blade size)
Closer	Dorma Door Controls Ltd TS73V and Briton 2003E surface mounted overhead closers	233 x 60 (footprint size)
Latch	Legge 'life' tubular mortise latch - disengaged	58 x 25 (forend size)
Furniture	Aluminium lever type handle	40 x 103 (footprint size)

14 Additional & Alternative Ironmongery

14.1 Latches & Locks

Latches and locks must either be as tested, or alternatively components with the following specification are acceptable:

Maximum forend and strike plate dimensions:	235mm high by 32mm wide by 6mm thick
Maximum body dimensions:	20mm thick by 150mm wide by 150mm high.
Intumescent protection:	See section 11
Materials:	All parts essential to the locking/latching action, including the latch bolt, forend and strike, to be steel or brass.

14.2 Hinges

Hinged doorsets must be hung on a minimum of 3 hinges, whilst leaves over 2250mm high must fit 4 hinges. Hinges with the following specification are acceptable:

Blade height:	90 - 120mm
Blade width (excluding knuckle):	32 - 40mm
Blade thickness	2.5 - 4mm
Fixings:	Equal number and nominally same pattern as tested
Materials:	Steel, stainless steel or brass
Hinge positions:	Top - 150-200mm from the head 2nd - 350mm from top hinge or equispaced between top and bottom when using 3 hinges Bottom - 180-250mm from foot 4th - equispaced between second and bottom (where required)
Intumescent protection:	See section 11

14.3 Automatic Closing

Automatic closing devices, must either be as tested or components of equal specification that can demonstrate contribution to the required performance of this type of 30 minute doorset design, when tested to BS476: Part 22: 1987 or BSEN 1634-1: 2000.

Note: Floor spring top pivots must be protected with intumescent gaskets in accordance with section 11.

14.4 Flush Bolts

Flush bolts may be incorporated into the top and bottom of the meeting edge of the inactive leaf of a double doorset, provided that the following maximum dimensions are not exceeded:

- 200mm long x 20mm deep x 20mm wide.

The mechanisms of the flush bolts must be of steel and the mortice must be lined on all edges with intumescent gaskets in accordance with section 11. The mortice must be as tight to the mechanism as is compatible with its operation.

14.5 Pull Handles

These may be surface-fixed or bolted through the door leaf provided that they are steel or brass and the length is limited to 1000mm. No additional intumescent protection is required provided that the hole for the bolt through the leaf is tight.

14.6 Push Plates/Kick Plates

Face-fixed ironmongery such as push plates and kick plates may be fitted to the doorsets providing they do not exceed 30% of the door leaf area.

14.7 Door Selectors

These may be freely applied, provided that they are not invasive of the leaf edges or door frames. Those that are invasive will require fire resistance test/assessment evidence to support their use. No additional intumescent protection is required unless test evidence dictates otherwise.

14.8 Panic Ironmongery

Panic ironmongery may be fitted, provided that its installation does not require the removal of any timber from the leaf, stop or frame reveal and it in no way interferes with the self-closing action of the door leaf.

14.9 Door Security Viewers

Door security viewers with brass or steel bodies and glass lenses may be fitted, providing they have been tested to 30 minutes integrity in this type of timber composite doorset design, in accordance with BS476: Part 22: 1987 or BSEN 1634-1: 2000. Any intumescent materials used for protecting the product during testing must be replicated.

14.10 Air Transfer Grilles

Air transfer grilles may be fitted providing the product has suitable test evidence to BS 476: Part 22: 1987 or BSEN 1634-1: 2000 that demonstrates a minimum 30 minutes integrity performance when installed within a timber based doorset of comparable thickness. Margins to the leaf edges will remain as referenced for glazing and the position of the unit will be dictated by the pressure regime tested in the proving evidence (normally below mid height). The area occupied by the air transfer grille must not exceed 0.1m².

14.11 Acoustic, Weather and Dust Seals

Silicon based acoustic, weather and dust seals may be fitted to this doorset design with out compromising the performance, providing their fitting does not interfere with the activation of the intumescent seals or hinder the self closing function of the leaves:

15 Door Gaps

Leaf to frame and leaf to leaf gaps must be representative of those tested. If substantially different gaps are employed, the fire resistance performance of this doorset design may change. As a general guideline, gaps should not exceed 4mm, except for the threshold, where 10mm is acceptable to allow for floor coverings. Door leaves must not be proud of each other or from the doorframe by more than 1mm.

16 Fixings

The supporting construction must be capable of staying in place and intact for the full period of fire resistance required from the doorset. The frame jambs are to be fixed to the supporting construction using steel fixings at 600mm maximum centres. The fixings must be of the appropriate type for the supporting construction and must penetrate to a minimum depth of 40mm. It is not necessary to fix the frame head, although packers must be inserted.

17 Sealing to Structural Opening

The door frame to structural opening gap must be protected using one of the following methods:

1. Gaps up to 20mm must be tightly packed with mineral fibre capped with a 10mm depth of a tested acrylic intumescent mastic on both sides (a 10mm x 10mm shadow gap may be used with this detail).
2. Full depth timber/timber based composite material or non-combustible subframe up to 20mm thick, with gaps up to 10mm between components sealed with a 10mm depth of a tested acrylic intumescent mastic on both sides or full depth tested expanding PU foam.
3. Full depth timber/timber based composite material or non-combustible subframe up to 40mm thick, with no gaps between the components and fitted with a minimum of 10mm thick architraves.
4. Gaps up to 20mm filled with proprietary product tested for similar gap filling applications to the required integrity (e.g. expanding PU foam or preformed compressible intumescent foam)

Guidance for various methods of sealing the frame to structural opening gap is also given in BS 8214: 1990, "Code of practice for fire door assemblies with non-metallic leaves", which may be referred to where appropriate.

18 Smoke Control

If the doorset design is required to provide a smoke control function to comply with Building Regulations, then it must be fitted with a smoke seal or combined intumescent/smoke seal, that has been tested in accordance with BS 476: Part 31: Section 31.1 and demonstrated to maintain the leakage rate below 3m³/m/h when tested at 25Pa. Providing the smoke seals, any interruptions, door gaps, type/configuration of door is consistent with the tested detail, then the doorset will comply with current smoke control legislation and a suffix 'S' may be added to the designation. Any other installed components through which leakage may occur must also be taken into account in the calculation.

Note: The incorrect specification and fitting of smoke seals may impair the operation of a fire resisting doorset assembly such that integrity is reduced, or in the extreme case completely diminished.

19 Conclusion

It is our opinion that, if the Moralt Lamincore doorset design constructed in accordance with the specification documented in this global assessment, were to be tested in the appropriate configuration in accordance with BS476: Part 22: 1987, it would provide a minimum of 30 minutes integrity.

20 Declaration by the Applicant

- 1) We the undersigned confirm that we have read and comply with obligations placed on us by FTSG Resolution No 82: 2001.
- 2) We confirm that the component or element of structure, which is the subject of this assessment, has not to our knowledge been subjected to a fire test to the Standard against which this assessment is being made.
- 3) We agree to withdraw this assessment from circulation should the component or element of structure be the subject of a fire test to the Standard against which this assessment is being made.
- 4) We are not aware of any information that could adversely affect the conclusions of this assessment.
- 5) If we subsequently become aware of any such information we agree to ask the assessing authority to withdraw the assessment.

Signed

Name:

For and on behalf of Moralt Tischlerplatten GmbH & Co. KG.

21 Limitations

The following limitations apply to this assessment:

- 1) This assessment addresses itself solely to the elements and subjects discussed and does not cover any other criteria. All other details not specifically referred to should remain as tested or assessed.
- 2) This assessment is issued on the basis of test data and information to hand at the time of issue. If contradictory evidence becomes available, CIF reserves the right to withdraw the assessment unconditionally but not retrospectively.
- 3) This assessment has been carried out in accordance with Fire Test Study Group Resolution No 82: 2001.
- 4) Opinions and interpretations expressed herein are outside the scope of UKAS accreditation.
- 5) This assessment relates only to those aspects of design, materials and construction that influence the performance of the element(s) under fire resistance test conditions. It does not purport to be a complete specification ensuring fitness for purpose and long-term serviceability. It is the responsibility of the client to ensure that the element conforms to recognised good practice in all other respects and that, with the incorporation of the guidance given in this assessment, the element is suitable for its intended purpose.

22 Validity

- 1) The assessment is valid initially for a period of five years from the date of issue, after which time it is recommended that it be submitted to Chiltern International Fire Ltd for reappraisal.
- 2) This assessment report is not valid unless it incorporates the declaration given in Section 20 duly signed by the applicant.

Prepared by:

Checked by:

Signature:

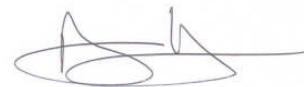
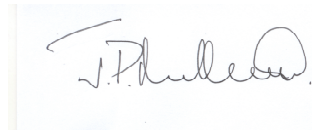

Name:

J P Mullett

P N Barker

Title:

Principal Consultant

Consultant

The legal validity of this report can only be claimed on presentation of the complete report.

Appendix A

Tests and Assessments

Primary Data

Test/ Assessment No	Configuration	Leaf Size (mm)	Standard	Performance (mins)
Chilt/RF07028	ULSADD	2300 x 1050 x 44	BS476 Pt 22	33
J84871/1	A: LSASD	2760 x 915 x 44	BS476 Pt 22	44
	B: LSASD	2440 x 915 x 44	BS476 Pt 22	46
CFR0706151*	ULSASD+OP	1728 x 950 x 44+100op	BS476 Pt 22	38

Key

LSASD = Latched single acting single doorset
 ULSASD+OP = Latched single acting single doorset with overpanel
 ULSADD = Unlatched single acting double doorset

* The furnace pressure in this test simulated a 2040mm high door.

Appendix B

Proprietary 30 Minute Glazing Systems

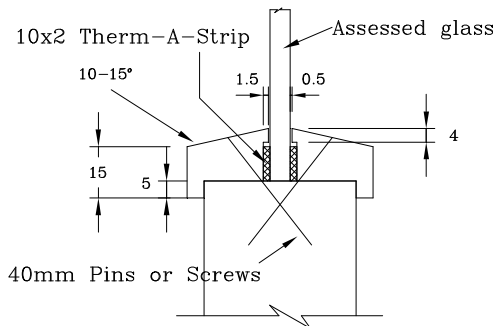

Intumescent Seals Ltd
Therm-A-Strip

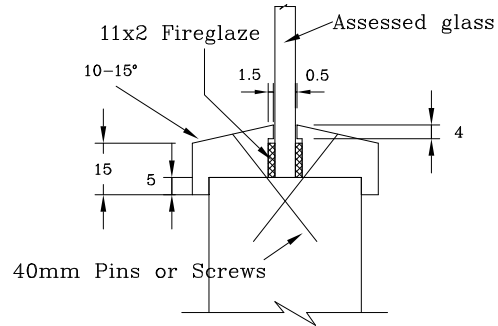

Sealmaster Ltd
Fireglaze

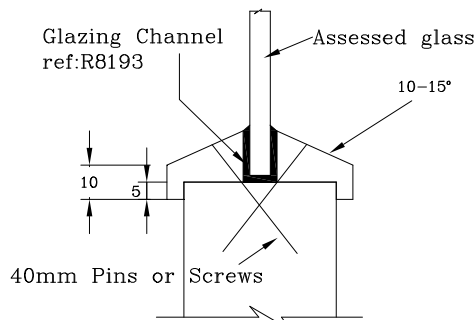

Reddiplex Group Plc

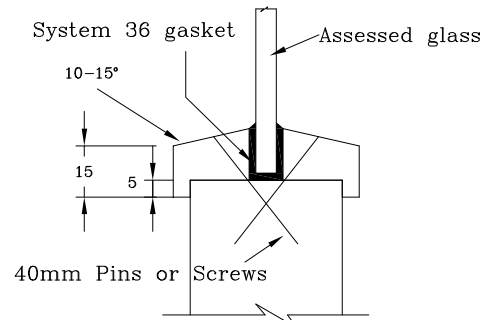

Lorient Polyproducts Ltd
System 36

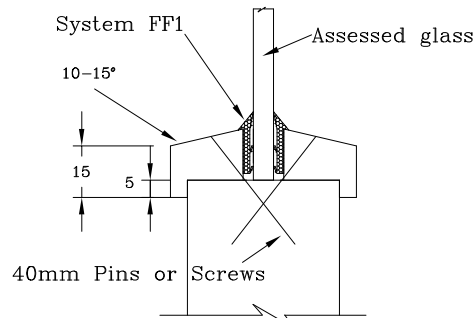

Lorient Polyproducts Ltd
System FF1

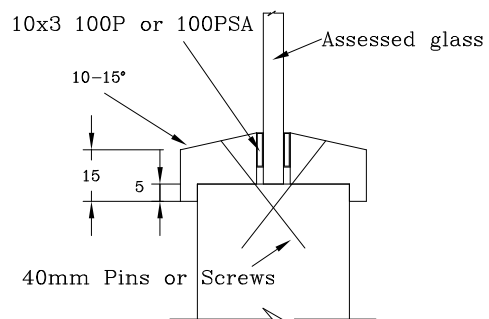

Mann McGowan Ltd
Pyroglaze 30

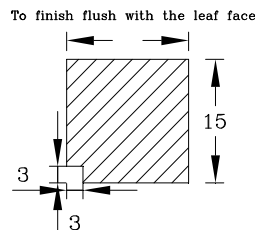

The bead shape above may be used with the following glass types and appropriate glazing system:

- 7mm Pyrobelite
- 7mm Pyrodur Plus
- 10mm Pyrodur
- 12mm Pyrobel
- 14mm Swissflam Lite
- 15mm Pyrostop
- 16mm Pyrobel

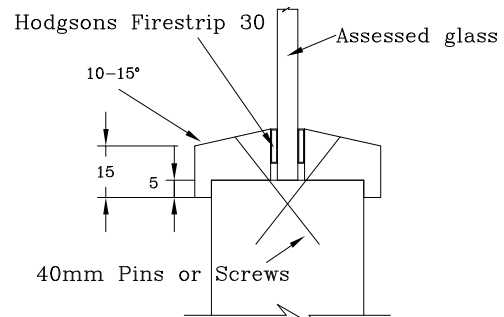

Hodgsons Sealants Ltd
Firestrip 30

The legal validity of this report can only be claimed on presentation of the complete report.

Appendix C

Revisions

Revision No	Date	Description

The legal validity of this report can only be claimed on presentation of the complete report.

Appendix D

Data Sheets for:

Moralt

Lamincore Doorsets

30 Minutes Fire Resistance

To be Read in Conjunction with Assessment No. Chilt/A07154

The legal validity of this report can only be claimed on presentation of the complete report.

Moralt Lamincore Doorsets – 30 Minutes Fire Resistance

Latched & Unlatched Single & Double acting Single Leaf Doorsets with Flush & Rebated Overpanels

Leaf sizes	Configuration	Height (mm)		Width (mm)	
	LSASD+OP	From:	2040	x	1098
To:		2355	x	950	
ULSASD+OP & DASD+OP	From:	2040	x	1073	
	To:	2305	x	950	
Max. Overpanel height (mm)		500			
Glazing	Max. glazed area:	0.72m ²			
	Approved systems:	See section 6 & appendix B			
Frame specification	Min. Section (mm):	70	x	32	
	Material:	Softwood or hardwood			
	Density:	Min 510kg/m ³			

INTUMESCENT MATERIALS - Intumescent Seals Ltd -Therm-A-Seal (graphite based seals)

HEAD:

Square Lipping: 1 No. 20 x 4mm strip fitted centrally in the leaf head or in the bottom edge of the overpanel

Rebated Lipping: 2No 10 x 4mm strips one strip fitted centrally in the rebate of the leaf head and one in the overpanel

JAMBS:

1 No 15 x 4mm fitted centrally in the frame reveal or leaf/overpanel edges

IRONMONGERY:

For additional protection to ironmongery see section 11

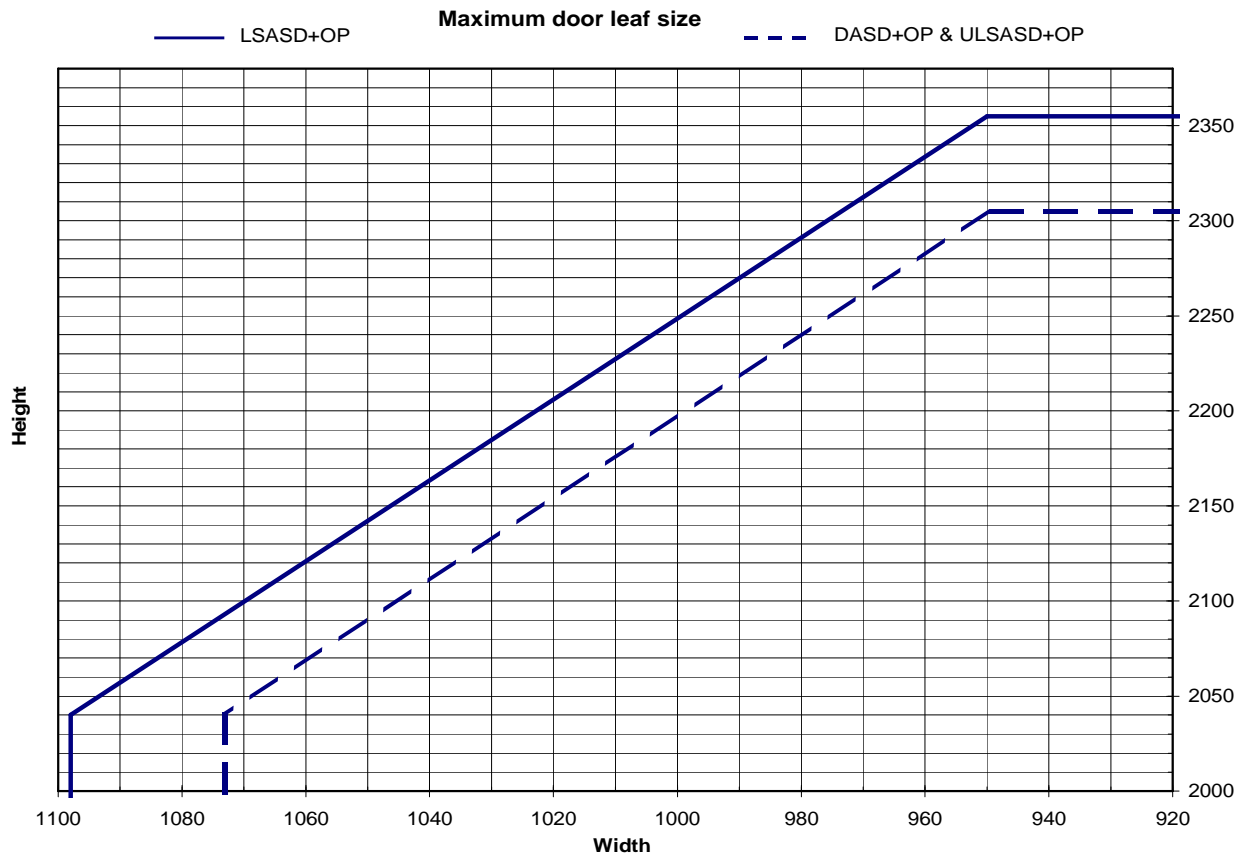

The legal validity of this report can only be claimed on presentation of the complete report.

Moralt Lamincore Doorsets – 30 Minutes Fire Resistance

Latched and Unlatched Single and Double acting Single Leaf Doorsets

Leaf sizes	Configuration	Height (mm)		Width (mm)	
	LSASD	From:	2760	x	1125
To:		3395	x	915	
ULSASD & DASD	From:	2300	x	1152	
	To:	2515	x	1050	
Max. Overpanel height (mm)	Transomed	2000			
Glazing	Max. glazed area:	0.72m ²			
	Approved systems:	See section 6 & appendix B			
Frame specification	Min. Section (mm):	70	x	32	
	Material:	Softwood or hardwood			
	Density:	Min 510kg/m ³			
<p>INTUMESCENT MATERIALS - Intumescent Seals Ltd -Therm-A-Seal (graphite based seals)</p> <p>HEAD: 1 No. 20 x 4mm strip fitted centrally in the frame reveal or leaf heads</p> <p>JAMBS & TRANSOMED OVERPANELS: 1 No 20 x 4mm strip fitted centrally in the frame reveal or leaf edges and around all edges of transomed overpanels.</p> <p>IRONMONGERY: For additional protection to ironmongery see section 11</p>					

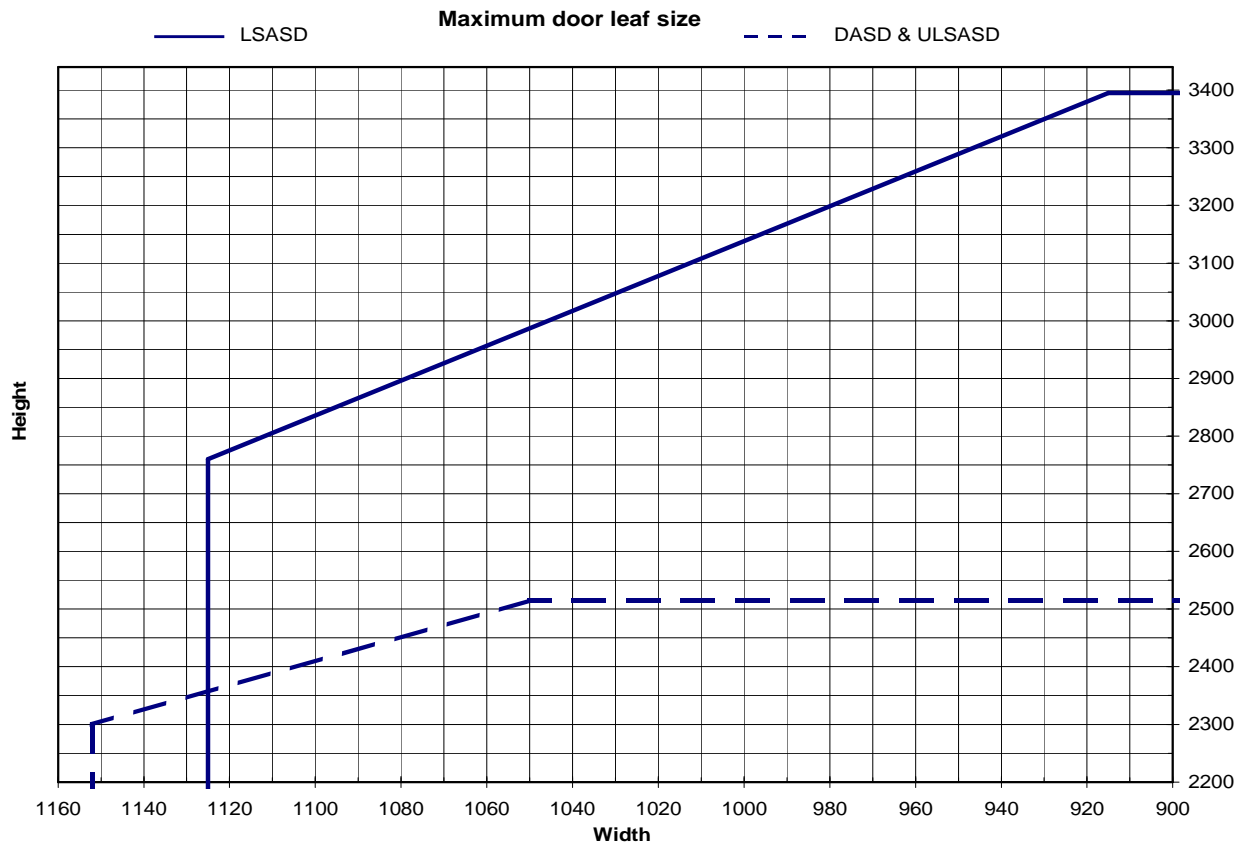

The legal validity of this report can only be claimed on presentation of the complete report.

Moralt Lamincore Doorsets – 30 Minutes Fire Resistance

Latched and Unlatched Single Acting and Double Acting Double Doorsets

Leaf sizes	Configuration		Height (mm)	Width (mm)
	LSADD	From:		2300
To:			2465	x 1050
ULSADD & DADD	From:		2300	x 1102
	To:		2415	x 1050
Max. Overpanel height (mm)		Transomed	1500	
Glazing		Max. glazed area:	0.72m ²	
		Approved systems:	See section 6 & appendix B	
Frame specification		Min. Section (mm):	70	x 32
		Material:	Softwood or hardwood	
		Density:	Min 510kg/m ³	

INTUMESCENT MATERIALS - Intumescent Seals Ltd -Therm-A-Seal (graphite based seals)

HEAD:
1 No. 20 x 4mm strip fitted centrally in the frame reveal or leaf heads

MEETING EDGES:
1 No 20 x 4mm strip fitted centrally in the edge of one leaf only

JAMBS & TRANSOMED OVERPANELS:
1 No 20 x 4mm strip fitted centrally in the frame reveal or leaf edges and around all edges of transomed overpanels.

IRONMONGERY:
For additional protection to ironmongery see section 11

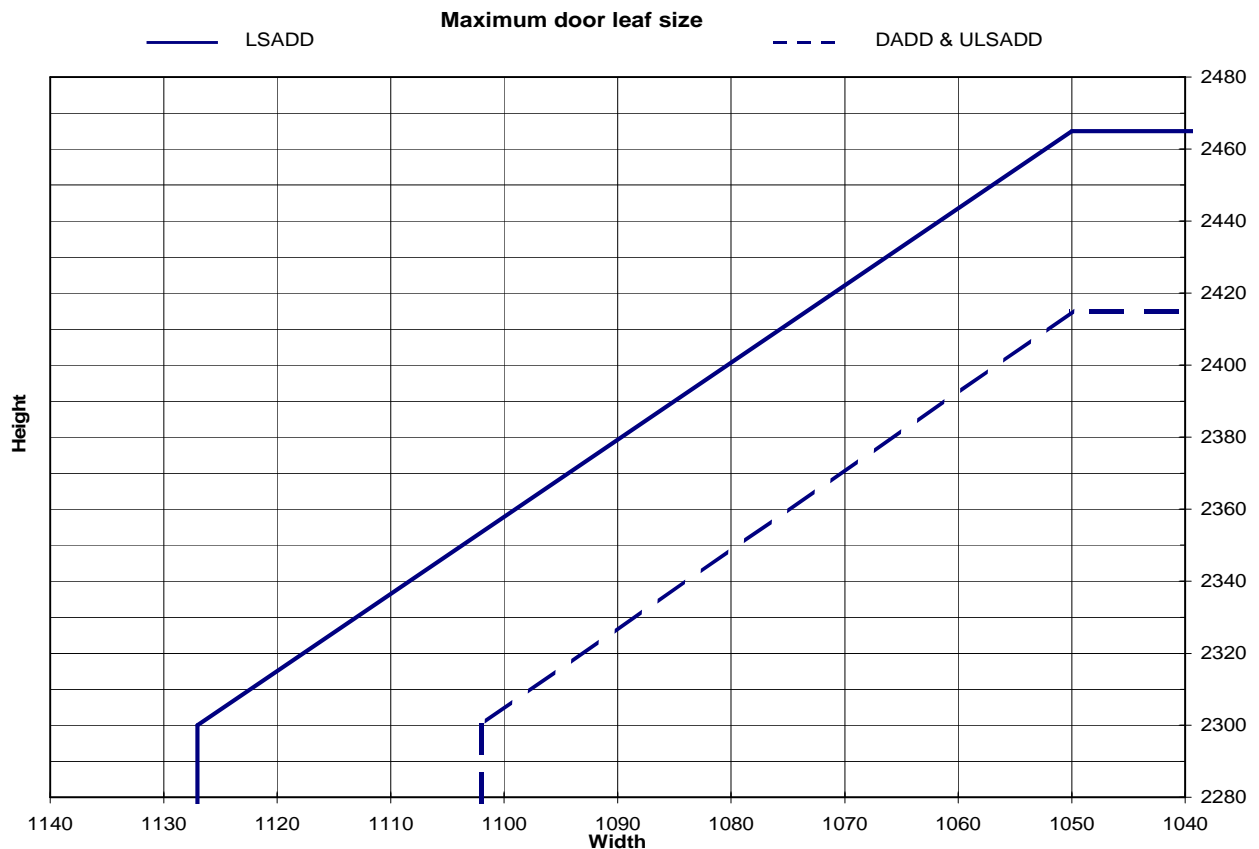

The legal validity of this report can only be claimed on presentation of the complete report.